



Western Washtenaw Construction Authority

Deck Specifications

Footings for attached decks:

R403 Footings shall be supported on undisturbed Natural soils or engineered fill.

No post to be located closer than 36" to the house Unless it rests on undisturbed soil.

R403.1.4 Footings for deck and stairs must extend A min. of 42" below actual grade

A footing inspection is required after holes are dug and cleaned out and prior to placing anything in the hole

Ledger Board

R507.2.1 (1) Ledger boards shall be bolted to the house. (2" from the top and bottom/between 2" & 5" from ends and shall be staggered)

R507.2.1 Decks cannot be supported upon masonry veneer.

R507.2.4 Attachment for lateral loads must be anchored home floor system

R703.1 Flashing shall extend under existing siding and over the ledger board.

Decks cannot bear on existing cantilever from home, without engineered approval. Sealed letter required.

Beams

R301.4 & R301.5 Beams shall consist of a minimum of 2-2x with posts spaced to provide a min of 50 lb/sq.ft. load.

Joists

Floor joists shall be designed according to table R507.4 When required, joist hangers shall be triple dipped galvanized or better. Joists shall be supported laterally by attachment to a header, band or rim joist.

Stairs

R311 - *Max Riser height - 8 1/4" *Min Tread depth - *9" measured nose to nose - Nosing Minimum 3/4" - Maximum 1 1/4" *Minimum Width - 36"

The greatest riser height within a flight of stairs shall Not exceed the smallest by more than 3/8 inch.

Openings in adjoining risers may not permit the Passage of a 4" sphere when total rise of stairs Exceeds 30 inches.

Handrails

R311.7.8 A graspable handrail is required when there are 4 or more risers. The handrail measured vertically from the tread nosing shall be 34" minimum and 38" maximum. Handrail ends shall be Returned. Handrails shall have a space not less than 1 1/2" between the wall and handrail. Handrail outside diameter: Circular: Minimum 1 1/4" - Max 2" Non Circular: Max cross sections = 2 1/4".

Guardrails

R312.1 All decks located more than 30" above adjacent grade shall have a guardrail not less than 36" in height, measured vertically above adjacent walking surface or adjacent fixed seating. Adjacent grade shall be measured 36" horizontally from Exterior edge of deck.

R312.1 No opening in guardrail may permit the passage of a 4" sphere.

Guardrails and handrails must be able to withstand a 200 lb. force in any direction.

Miscellaneous

R317 All framing members shall be pressure treated. All fasteners shall be hot dipped-zinc coated galvanized steel, stainless steel, silicon bronze or copper.

A rough framing inspection is required prior to the placement of decking if the bottom side of Joists is closer than 18" to the ground or if underside of deck will be concealed by skirting or other means.

A final inspection is required upon completion.

TABLE R507.6
DECK BEAM SPAN LENGTHS^{a,b} (ft. - in.)

SPECIES ^c	SIZE ^d	DECK JOIST SPAN LESS THAN OR EQUAL TO: (feet)						
		6	8	10	12	14	16	18
Southern pine	2 - 2 x 6	6-11	5-11	5-4	4-10	4-6	4-3	4-0
	2 - 2 x 8	8-9	7-7	6-9	6-2	5-9	5-4	5-0
	2 - 2 x 10	10-4	9-0	8-0	7-4	6-9	6-4	6-0
	2 - 2 x 12	12-2	10-7	9-5	8-7	8-0	7-6	7-0
	3 - 2 x 6	8-2	7-5	6-8	6-1	5-8	5-3	5-0
	3 - 2 x 8	10-10	9-6	8-6	7-9	7-2	6-8	6-4
	3 - 2 x 10	13-0	11-3	10-0	9-2	8-6	7-11	7-6
	3 - 2 x 12	15-3	13-3	11-10	10-9	10-0	9-4	8-10
Douglas fir-larch ^e , hem-fir ^e , spruce-pine-fir ^e , redwood, western cedars, ponderosa pine ^e , red pine ^f	3 x 6 or 2 - 2 x 6	5-5	4-8	4-2	3-10	3-6	3-1	2-9
	3 x 8 or 2 - 2 x 8	6-10	5-11	5-4	4-10	4-6	4-1	3-8
	3 x 10 or 2 - 2 x 10	8-4	7-3	6-6	5-11	5-6	5-1	4-8
	3 x 12 or 2 - 2 x 12	9-8	8-5	7-6	6-10	6-4	5-11	5-7
	4 x 6	6-5	5-6	4-11	4-6	4-2	3-11	3-8
	4 x 8	8-5	7-3	6-6	5-11	5-6	5-2	4-10
	4 x 10	9-11	8-7	7-8	7-0	6-6	6-1	5-8
	4 x 12	11-5	9-11	8-10	8-1	7-6	7-0	6-7
	3 - 2 x 6	7-4	6-8	6-0	5-6	5-1	4-9	4-6
	3 - 2 x 8	9-8	8-6	7-7	6-11	6-5	6-0	5-8
	3 - 2 x 10	12-0	10-5	9-4	8-6	7-10	7-4	6-11
	3 - 2 x 12	13-11	12-1	10-9	9-10	9-1	8-6	8-1

For SI: 1 inch = 25.4 mm, 1 foot = 304.8 mm, 1 pound per square foot = 0.0479 kPa, 1 pound = 0.454 kg.

- a. Ground snow load, live load = 40 psf, dead load = 10 psf, L/Δ = 360 at main span, L/Δ = 180 at cantilever with a 220-pound point load applied at the end.
- b. Beams supporting deck joists from one side only.
- c. No. 2 grade, wet service factor.
- d. Beam depth shall be greater than or equal to depth of joists with a flush beam condition.
- e. Includes incising factor.
- f. Northern species. Incising factor not included.

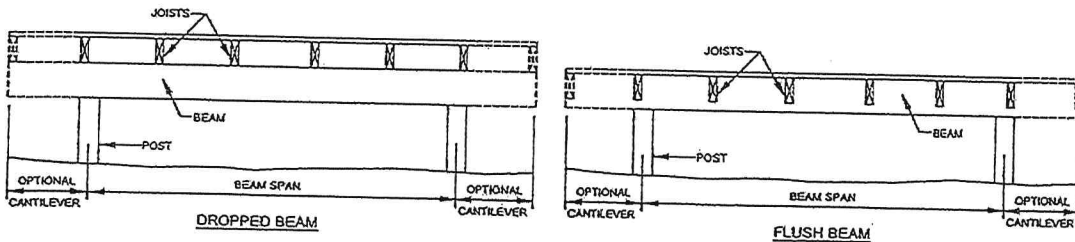
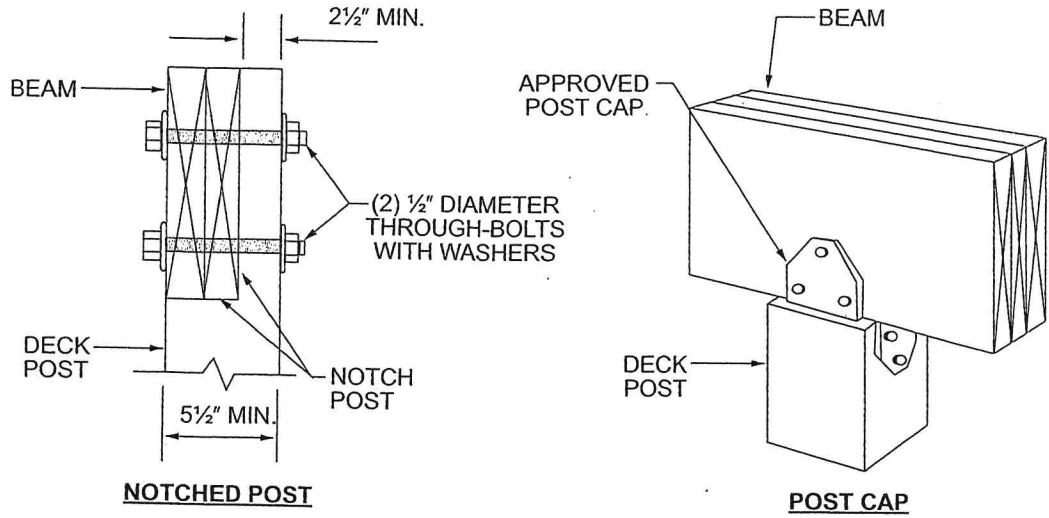

FIGURE R507.6
TYPICAL DECK BEAM SPANS



For SI: 1 inch = 25.4 mm.

FIGURE R507.7.1
DECK BEAM TO DECK POST

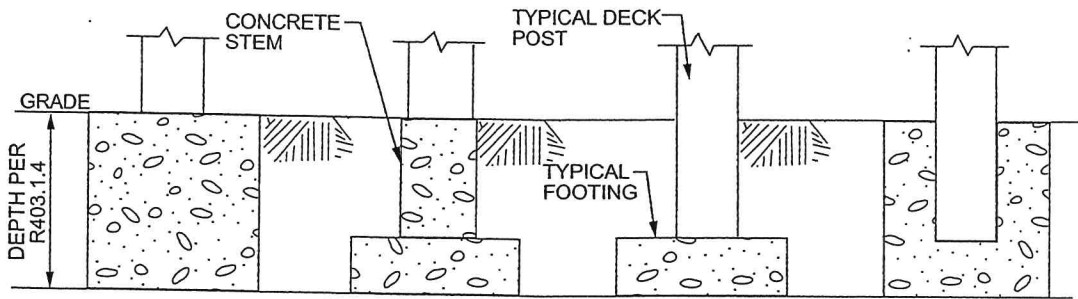

FIGURE R507.8.1
TYPICAL DECK POSTS TO DECK FOOTINGS

ALTERNATIVE LATERAL SUPPORT DETAIL

